



DracoDrum TM

User Guide and Installation Manual

Origin & Draco2

Nexus (300 & 200 series) and Vortex

Pump and Gravity fed systems

Please read all instructions before proceeding.

Thank you for your purchase of a DracoDrum. We wish you many happy years of use.

Contents of Box

Drum should come with - drum, controller, waste pipe (2 pieces), inlet pipe and baffle for nexus or inlet pipe, brackets and suspension bars for vortex.

Installation

Attaining Correct Water Level

When fitted,

Gravity mode, running water level should be near the top of the waste tray.

Pump fed mode, front mounted sensor should be about 35 -40mm above water level, which equates to just on or slightly below the base of the waste tray.

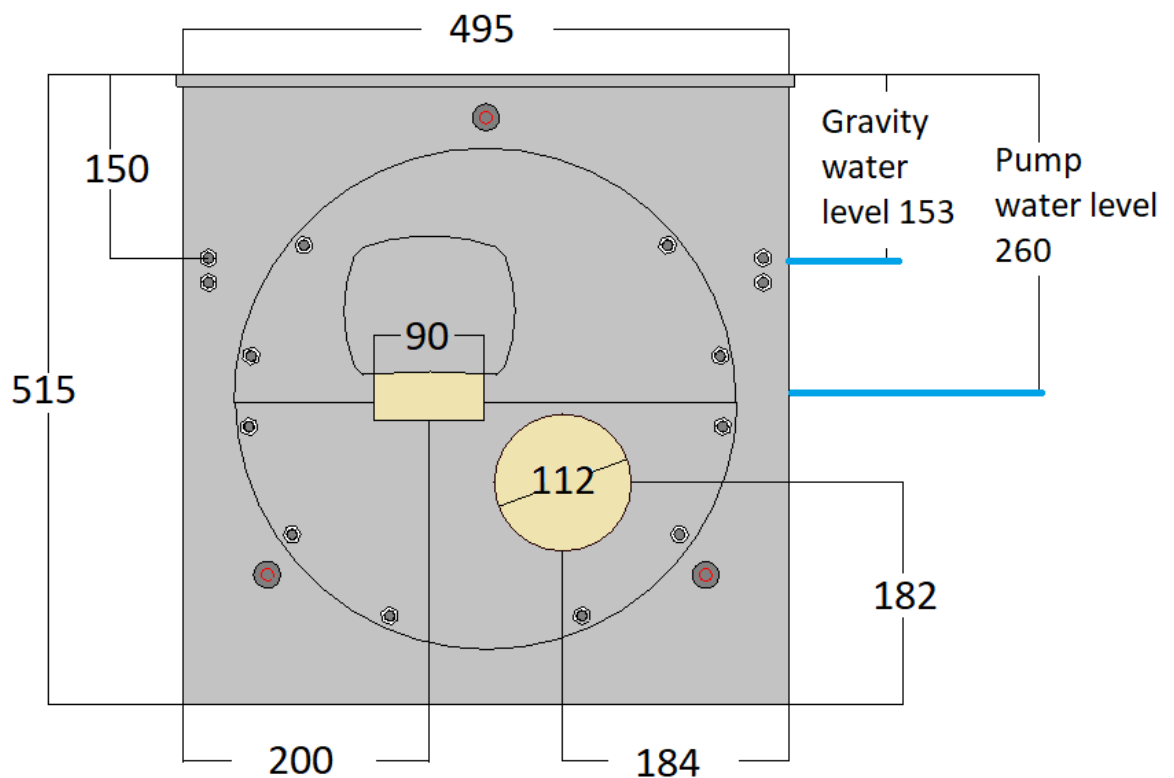

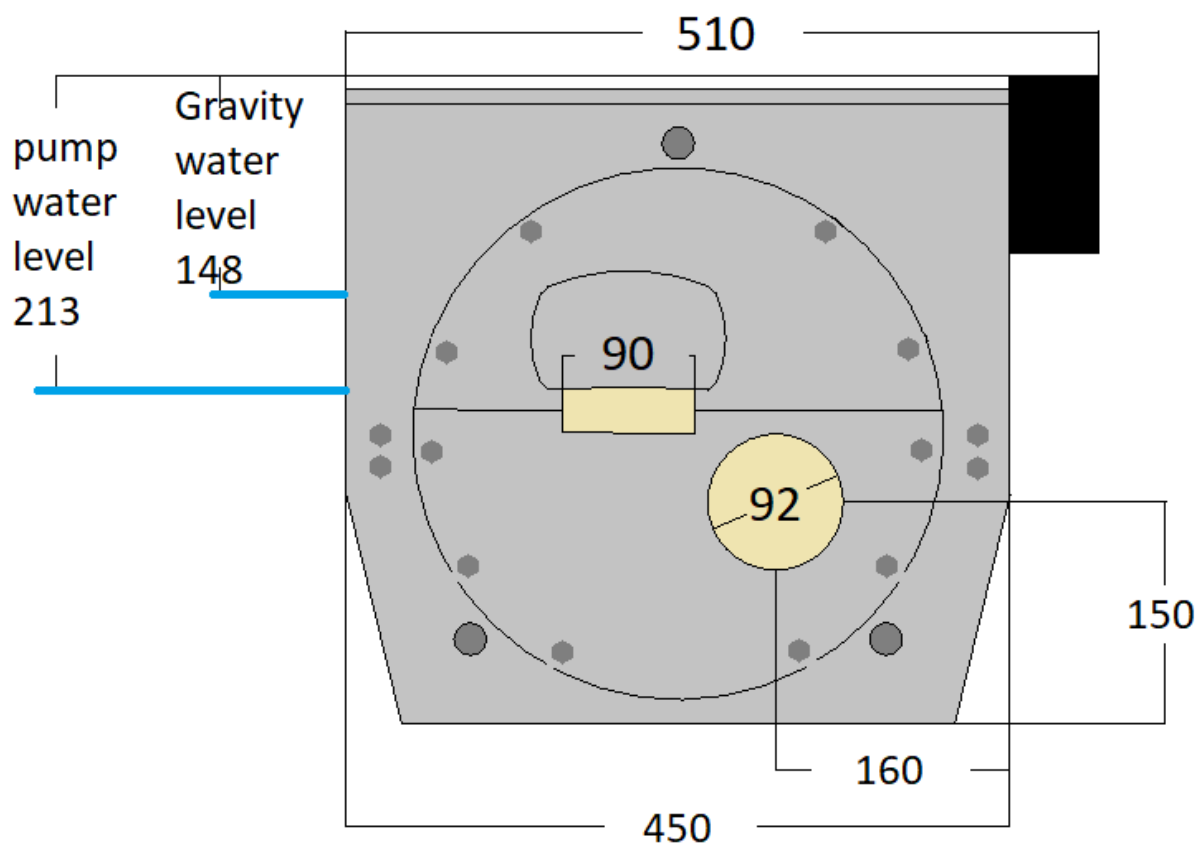

Brackets

Nexus 300 series, Fix brackets accordingly for 'Attaining correct water level', they have a number of holes to allow an adjustment of height. Wider brackets go on the front (waste tray side).

Nexus 200 series, Fix brackets accordingly for 'Attaining correct water level', they have a number of holes to allow an adjustment of height. **All brackets are the same, but they face inwards on the rear of the drum and outwards on the front of the drum** (waste tray side).

Vortex, Fix brackets accordingly for 'Attaining correct water level' they have a number of holes to allow an adjustment of height. They are left and right handed.

Attach Waste Pipe

The waste pipe comes in 2 parts, a lower 50mm pipe and an upper 60/90mm section. Slot these 2 together using the rubber boots provided.

Nexus (200 & 300 series), remove easy/foam/answer.

Vortex, remove central pipe and any other internal obstruction.

Then insert the pipe into the waste outlet of the nexus, giving it a good wiggle to ensure a watertight fit. Make sure all jubilee clips are loose so pipe length can be adjusted to match up with height of drum. For vortex, bore a 65mm hole through the side of the vortex and fit tank connector. Use the 65mm flexi from drum waste to tank connector, trimming as needed and secure with the jubilee clips provided.

Adjust waste pipe so that it connects with the 90mm waste outlet on the tray. A tip here - if there is extra pipe protruding from any of the rubber boots' internal "steps", it is an idea to cut this off so there is a smooth progression for waste. In the case of the nexus, if the pipe is too long, it will push up the waste tray, bend the bottom of the waste tray plate outwards, which will cause dirt to get past the drum. Shorten the pipe so this does not happen.

Attach Inlet Pipe

Attach inlet pipe to front of the drum. This is the aperture in the lower semi-circular plate on the front of the drum. 110mm on the Origin, 90mm on the Draco2.

Nexus 300 series - Place drum into nexus, slotting inlet pipe baffle firmly into the slot on the inlet channel on the nexus.

Nexus 200 series – Place drum into nexus, slotting inlet pipe baffle firmly into the slot on the inlet channel on the nexus. **NB** there is an extra plate in the kit. This needs screwing down over the top of the baffle plate using the supplied self tapping screws. 2 x 4mm holes should be drilled in the nexus, using the plate as a guide, to allow this. Be careful when tightening as the plastic the Nexus is made of is very soft.

With both of the above, if the inlet pipe is pushing on the drum excessively causing sideways stress, it may need to be shortened. In cold temperatures, it may be worth warming the pipe up to allow it to bend correctly when installed.

Vortex - push inlet flexi pipe onto the gasket/pipe and push that into incoming tangential orifice. Place drum into the vortex, attach flexi pipe to the inlet pipe on the drum.

Controller

Mount it within 15 feet (4.5metres) of the drum.



Make sure the emergency stop switch is pressed in before plugging the unit in

Connect umbilical to the drum - it is keyed and the key always points away from the drum body. The controller should already be set to the voltage of your country.

Connecting the Water

Water valve operated spray bars, connect your incoming water supply to the valve. In the UK this should be via a standard 15mm pipe. For international, an adaptor will be required and the valve body uses a standard 3/4" BSP female thread. Rotate the Valve so the black part is pointing upwards.

Optional Pressure Pump spray bars the above can be ignored as the water is taken from the central chamber of the nexus or vortex.

Making Adjustments

Your DracoDrum allows you to make 2 adjustments to it, the length of the wash and the height of the water sensors.

Rotations per wash

You can select between 1 and 4 periods per wash. A period is *not* a full rotation but rather lasts for approximately 30 seconds. This is to ensure the same part of the screen is not constantly underwater and all parts of the drum are used equally.

To adjust the number of periods, simply turn the dial on the control box to the required number

NB: The system will over ride and continue to wash for more durations if the water level should not have reached the required minimum height that you have set with the internal water sensor after a wash.

Adjusting the height of the sensor



For gravity fed units the sensor is on the clean side of the drum. This sensor is triggered when the micron screen becomes dirty and blocked and the water level starts to drop as not enough water is able to get through.

With the system running, and the drum has just washed, you will have behind the drum what is referred to as "running water level". This can and usually is lower than if the main circulation pump

is turned off. To maximise the area of filter screen under water, the waste tray should be half submerged at this running water level. The float switch should then be set so that the floating tip of it is approximately 5mm below that.

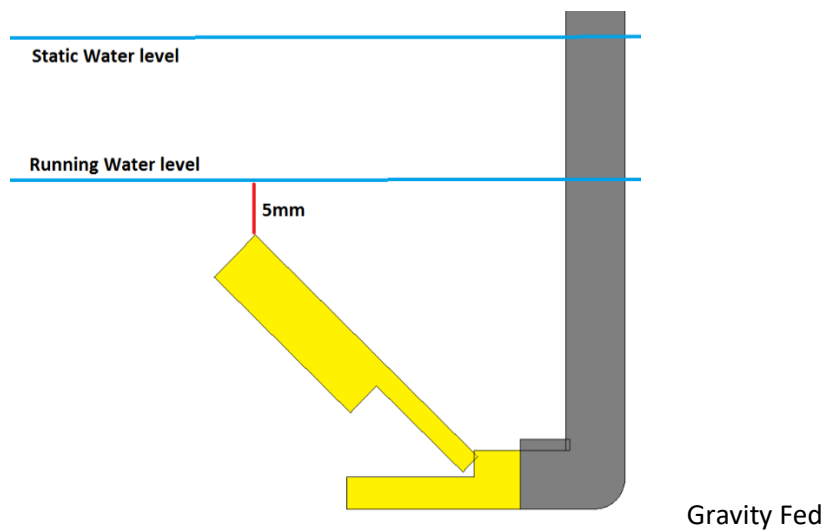

For pump fed units the sensor is on the dirty side of the drum and is triggered by a rise of water level as the screen is blocked. The water level in this case should be just below the bottom of the waste tray and the suspended float switch should be just touching the water.

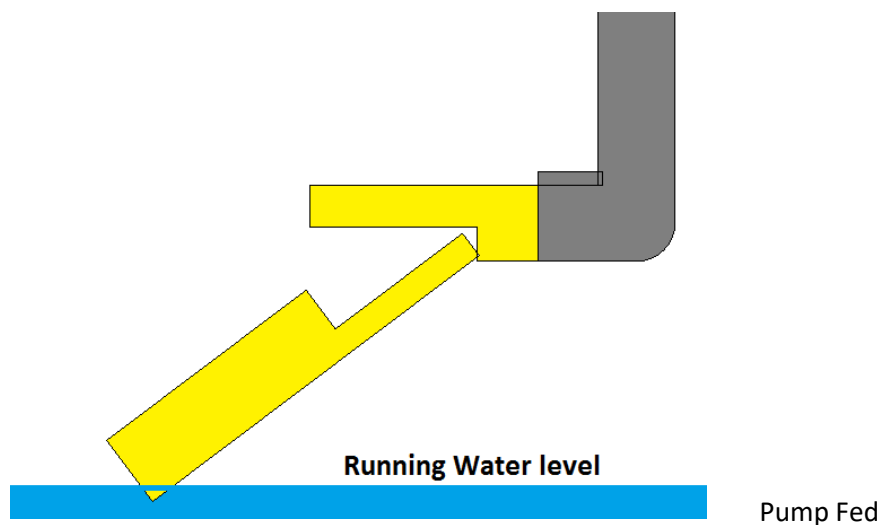

The unit will continue to wash for as many rotations as necessary until the water level reaches the required height to re-cover this sensor. E.g. if you have your unit set to only 1 rotation but a single rotational cycle is not enough to clear the debris attached to the micron screen then it will continue to rotate and clean until the sensor is re-submerged in water. If however you have the system set to four rotational cycles even if one rotation clears the screen and allows the water to return to the normal running height the unit will continue for the specified number of cycle rotations.

Starting your Drum for the First Time

Turn on controller by twisting and unlocking the stop button. You should see a green light and a red zero. The drum is now ready to go.

Operation

When running, the drum should show a green light to confirm power is on. Initially you will see a red zero to the right of the unit. This will change as it displays the minutes between the last 2 washes. When triggered, the red sensor led will flash. This flashing will only occur whilst the sensor is actually triggering or whilst you are pressing the green button in. Once triggered this initiates a wash "cycle" and 2 blue leds will light. One for the wash pump and one for the drive motor.

A wash cycle is approximately 30 seconds. Once the 30 seconds is up, the blue leds will extinguish and the drum will stop. If the red led continues to flash, the drum will continue to wash until the red led stops flashing. If this situation lasts for more than 4 minutes, the drum will auto stop, wait for 2 minutes and then continuously monitor the sensor. Once the sensor is no longer active, it will auto restart. Whilst it is monitoring, the red led will come on solidly (failsafe mode).

You can select up to 4 wash cycles for your wash duration, so you can set the drum to wash for up to 2 minutes each time. If you need to manually trigger a wash, for example maintenance, you can press the green button on the controller to start the drum. If there is an issue with the drum, pushing the emergency stop will shut off all power within the controller as a safety feature.

Timed wash Option

This works in conjunction with the auto wash NOT as an either/or scenario. The auto wash function has not changed.

The 'Wash override' allows you to choose between 3 settings, Off, 45, 99 (the latter 2 referring to minutes between washes). This forces the system into a wash at either 45 or 99 minutes since the last wash, or you can choose to not have this feature in use by leaving it on 'Off'.

If you select the 45 or 99 and your screen blocks, the auto wash will activate so it may be a case that your system has to wash much more frequently to deal with the solids within your system than either 45 or 99 minutes. As said it is a dual system, you cannot switch off the auto wash.

This may be particularly relevant in the winter months when reduced feeding, algae growth means you water stays quite clear in comparison to warmer months. In these instances the system auto trigger system will not be activated for longer periods of time.

Maintenance



NB always ensure the red Off Button is activated before doing anything within the drum to ensure it will not start a cleaning cycle

All drums at some point will either suffer from biofilm build-up or limescale deposits. This is easy to see on a Dracodrum Solum as the "time between washes" display will start to decrease.

Cleaning the Screen

Set the wash duration to 4, press the manual button and jetwash the screen with a standard nozzle, not a pulsating one. The nozzle should be about 3 to 4 inches from the screen to gain maximum benefit. Once done, set the wash duration back to how it was.

Waste Tray

Every fortnight or so (or more if there is a blanketweed/heavy leaf issue), power off the drum, unscrew the 6 bolts holding the waste tray on, disconnect the drain pipe and withdraw the waste tray. Make sure it is clean and then replace. All 6 bolts on the front of the drum holding the plate should be finger tight only. We actually use a socket without the ratchet to tighten them up in the factory.

General

Periodically it is wise to purge your filter. Although DracoDrum filters down to 58 micron, there are still particles smaller than this in the waste column. These can congregate within a filter and on our own heavily stocked system, a bi-monthly cleanout is usually carried out. You will get a feeling for how often you need to do this as every system is different. Also every 4 months it is advisable to remove the seal and check for wear or debris that may impede the drum.

Tips

All drum filtered systems should have a trickle in. This is crucial on a pressure pump wash system as the drum extracts water from the pond to wash itself. It is highly important in any event as you will now no longer be doing water changes by cleaning your filter. Failure to do so will likely result in a build up of nitrate (and increased algae and blanketweed issues) and a drop in Carbonate hardness (KH) and buffering capacity of the pond.

There may be a slight nitrite level increase after fitting any drum. This is down to a switchover in the type of nitrobacter inhabiting your system to a "clean loving" variety. This usually lasts no more than a couple of weeks and has not been seen to be detrimental to fish stocks.

Gravity fed systems, you can do a partial bottom drain purge by switching off your drum but not the circulation system. Allow the water level within the filter to drop as low as it can, then turn the drum back on. The backfilling water should increase flow down the bottom drain pipe and clean the pipe run. If using the optional pressure pump, allow the water level to drop to nearly the bottom of the inlet tube. You will not damage the wash pump by running it dry as it is self-priming.

If the pond is not entirely clear, it may be that the float switch is too low in the water for gravity fed systems or the drum is too high up for pump fed. If that is the case, the water pressure “differential” between the inside and the outside of the drum screen is too great and waste can extrude itself through the screen and cause the water quality to become turbid. Readjust the float switch higher in the water (gravity) or drop the drum lower in the water (pump) to resolve this.

Diagnostics

The DracoDrum should be virtually problem free, but like any electro mechanical device, it may occasionally need help. The 4 LED’s on the control panel can help to diagnose issues.

- **RED sensor led** goes solid (stops flashing) And drum stops washing after 4 minutes (drum failsafe mode – see paragraph 2 in “operation”)

Water sensor is too high (gravity) too low (pump fed). Reset height.

Waste Tray is full of dirt and is not expelling water - clean waste tray.

Screen is blocked but tray is empty (will be accompanied by low "time between washes" display), jetwash screen.

If screen is clean, maximum flow rate of the drum has been exceeded, so water level cannot return to running level. Reduce flow.

Tap fed systems – Water supply has been turned off/pressure reduced substantially. Check incoming water supply.

Failed / disconnected water valve – disconnect incoming water supply and visually check ball valve operation when pressing the “manual wash” button.

- Drum does not trigger, manual wash button has no effect

Green led is off - no power to controller.

Green led is on - umbilical is not correctly plugged into drum.

NB for pump fed, drum still refuses to trigger but above points are ok, remove waste tray and clean out float switch.

- BLUE LED’s continuously on, drum always washing and also no red flashing LED
- Only one blue LED comes on

Faulty control board in both cases - Contact dealer

- BLUE LED’s come on when triggered, drum rotates but no wash

Faulty or disconnected pressure pump or water valve. Check connections in the drum terminal box (there is a diagram within the box to make this easier).

- BLUE LED’s come on when triggered, drum washes but does not rotate

Faulty or disconnected drive motor - again check the drum terminal box.

- In wash cycle, motor rotates but drum does not

Drum is jammed. Turn drum off, remove waste tray and clear obstruction. Restart drum. If drum still does not rotate but motor shaft does, contact dealer.

- Water not coming through all jets in wash cycle

Undo blue holding cap on blocked jet by quarter turn and remove jet assembly. "blow backwards" into the jet with your mouth and this should clear the obstruction. Check the inside of the jet to see if the obstruction is now visible and remove. Replace jet.

In hard water areas, an old toothbrush applied to the jet should clean it. If this is unsuccessful, spare jets are available from your dealer.

Breakages

The DracoDrum is completely modular meaning that if you should have an accident, all parts are replaceable without having to buy a new drum.

We are able to supply your local dealer with all replacement parts, up to and including the chassis and drum itself, so that your drum can be fixed and up and running again in a short period of time.

DracoDrum Guarantee

This product comes with a 1 year 'Return to Base' guarantee for manufacturer faults, including the screen and all seals, which is valid from date of purchase.

In the first instance the consumer should contact the DracoDrum agent from which the unit was purchased. Proof of purchase will be required along with a serial number.

Any unauthorised repairs, modifications or alterations to this unit will invalidate the guarantee.

Liability is limited to replacement of the defective parts. This guarantee is not transferable. It does not affect your statutory rights. DracoDrum Ltd and its agents shall not be held liable for any consequential loss caused by or arising from the use of any DracoDrum products including loss of fish, plants or any other livestock as a result of any failure or defect of this product.

The guarantee undertaking consists at the option of DracoDrum the elimination free of charge of material and manufacturing defects through repair, exchange of parts or replacement of the entire product. If DracoDrum repairs the product, exchanges parts or replaces the product, then the guarantee claim for the defect in question or the replaced product is valid for the remaining duration of the original guarantee period.

In cases where, upon inspection, the fault is not covered by the manufacturer's guarantee, DracoDrum reserves the right to recover from the customer the costs of handling the guarantee claim.

DracoDrum reserves the right to alter product specifications without notification.

What isn't covered by the DracoDrum guarantee

There are some circumstances in which a DracoDrum guarantee doesn't cover the repair or replacement of a machine. These aren't hidden in the small print. Here's what isn't covered:

- Fair use wear and tear
- Accidental damage
- Damage caused by not carrying out the recommended maintenance.
- Damage from external sources such as transit, weather, electrical outages or power surges.
- Failures caused by circumstances outside of DracoDrum's control.
- Faults caused by:
 - Negligent use, misuse, neglect or careless operation of the unit;
 - Use of the unit which is not in accordance with the DracoDrum's User/Install Guide;
 - Use of parts not assembled or installed in accordance with the instructions of DracoDrum.
 - Use of parts and accessories which are not DracoDrum Genuine Components.
 - Repairs or alterations carried out by parties other than DracoDrum or its authorised agents.

Any dispute arising from the provisions of the manufacturer's guarantee will be dealt with under the laws of England and Wales.

